

What to do.....

if the downstream pressure rises above the set pressure in the case of a pressure reducing valve installed for the purpose of reducing pressure in a hot water system, the cause is very often due to pressure crossflow in a mixing valve, due to the fact that the cold water supply has not been fitted with a pressure reducer.

This occurs especially in the case of thermostatic mixing valves, single-lever mixing valves or normal two-tap mixing valves with clogged anti-splash nozzles.

Such faults can only be eliminated by installing the pressure reducing valve in the main supply line, thus reducing the pressure in both, the hot and cold water supply systems to the same level.

Spare parts

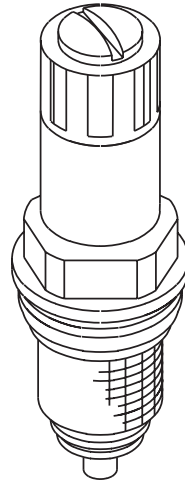

REDC312010 - Cold
REDC312015 - Hot

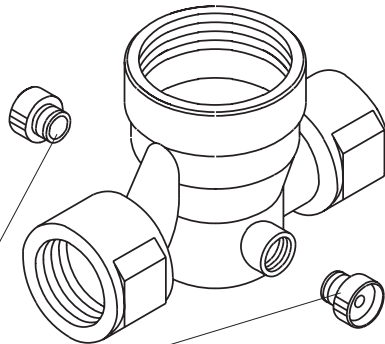

ZPLG221002

Reliance Worldwide Corporation (UK) Ltd
Horton Road
West Drayton
UB7 8JL
Tel: +44(0)1895 449 233
www.reliancevalves.com



Instructions for use

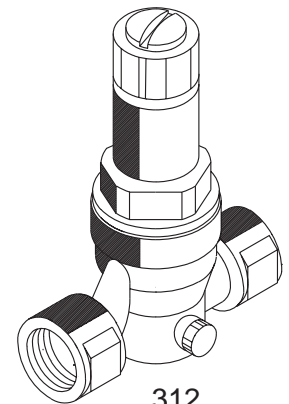
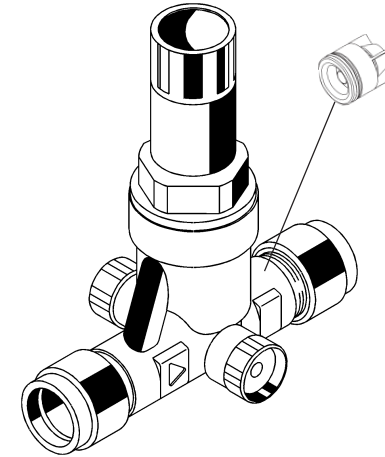

312

312 Series Pressure Reducing Valve

Field of application

The 312 Series Pressure Reducing Valve is used for reducing pressure in closed systems with media as given in the specifications below.

Design

Pressure reducing valve with balanced single-seated Internals and coaxially arranged strainer. The complete control unit can be exchanged by removing spring cap without any change to the downstream pressure setting. Several factory settings are available for downstream pressure, set or adjustable.

Body made of bronze / DZR material; spring cap high grade glass reinforced plastic; diaphragm and seals made of heat and age proof rubber elastic material, diaphragm reinforced by polyamide fabric inlay; spring made of spring steel wire, corrosion protected; all other inner parts made of steel 1.4305 / DZR-material; strainer made of corrosion protected steel, mesh width 0,25 mm.

Pressure gauge connection : Rp1/4 ISO228/1, both sides
Inlet pressure : max. 16 bar
Outlet pressure : 0,5 - 5 bar; factory setting 4 bar max.
Operating temperature : 60 °C water only
Media :

Reduction ratio : max. 10:1
Installation position : any orientation

Installation

The pressure reducing valve should be fitted free from stress into the water supply. Installation in the main supply is recommended to produce equal pressure values in the whole installation. The valve is protected against malfunction (caused by dirt particles) by an incorporated strainer (mesh width 0,25mm).

Operation

Open the isolating valves after the installation is complete. On models with adjusting knob, the pressure is adjustable between 0,5 and 5 bar (it is factory preset at 4 bar)(see Fig. A) :

- 1- Slacken the set screw in the handle.
- 2- Turn knob counterclockwise (-)
- 3- Open and close a tap downstream of the pressure reducer
- 4- Turn handle clockwise (+) to the desired pressure
- 5- Tighten set screw

On sealed models, the outlet pressure is indicated on the sealing disc (see Fig. B).

Fig. A

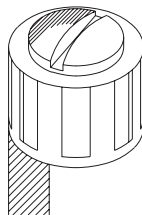
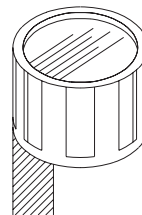

Fig. B



Maintenance

Under normal conditions the pressure reducing valve should not require any special maintenance.

If the outlet pressure increases to the same level as the inlet pressure, the valve seat may be clogged. If so, it will be necessary to clean the built in pressure reducer cartridge.

To do this,

- 1- Close isolating valves upstream and downstream of the pressure reducer
- 2- Unscrew cap
- 3- Remove the cap together with complete control unit
- 4- Rinse in clean water

Do not use any solvents to clean the strainer as this may cause damage to the plastic components of the valve.

The complete cartridge can now be replaced into the body. The pressure setting will not need to be reset due to the unique design of the valve.

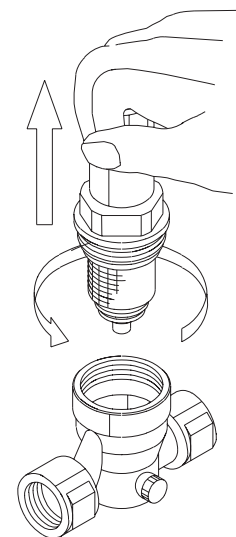

In cases where irreparable damage has been caused to the cartridge a spare cartridge can be purchased and fitted without the need to replace the entire valve.